

TOSHIBA

Leading Innovation >>>

Slim Ducted Heat Pump System



- New 3.6 kW SDI Model
- New slim 210mm deep ducted unit design
- Replacement Technology (R22 & R407c)
- All 'A' rated performance
- High-performance operation, using digital inverter design
- Static pressure up to 45 Pa
- Extremely quiet operation
- Twin split also available (model 564 only)
- Infra-red and wired controls available
- Operational to -15°C in cooling

The Slim Ducted unit is a very compact unit with low height dimensions for flexible ceiling installations.

The units are suitable for use with either new R410A refrigerant pipe work, or indeed can be used as 'replacement technology' enabling the re-use of existing R22 or R407c Pipe work.

Key features include high energy efficiency performances in cooling and heating and a choice of two selections for the air inlet section: bottom or back side.



Size 404 and 564

Model	Outdoor Unit	RAV	SP404AT-E	SP564AT-E
	Indoor Unit	RAV	SM404SDT-E	SM564SDT-E
System Data	Cooling Capacity (Range)	kW	3.6 (1.5-4.0)	5.0 (1.2-5.6)
	Heating Capacity (Range)	kW	4.0 (1.5-5.0)	5.6 (0.9-7.4)
	Power Input, Cooling/Heating	kW	1.03/1.00	1.56/1.44
	COP	W/W	4	3.89
	EER	W/W	3.5	3.21
	SEER	W/W	4.55	4.2
	Annual Power Consumption, Cooling	kWh	515	780
	Energy Label, Cooling / Heating		A/A	A/A
	UK Conditions - Cooling Capacity	kW	3.88	5.44
	UK Conditions - Sensible Cooling Capacity	kW	3.2	4.2
UK Conditions - Heating Capacity	kW	4.93	6.9	
Indoor	Air flow (High/Medium/Low)	l/s	145/167/192	162/188/217
	Sound Pressure Level (High/Medium/Low)	dB(A)	33/36/39	36/40/45
Outdoor	Airflow	l/s (m3/h)	667 (2400)	667 (2400)
	Sound Pressure Level (cooling/heating)	dB(A)	45/47	47/48
	Pipe Connections, Gas - Liquid	in	1/2 - 1/4	1/2 - 1/4
	Pipe Length, Maximum/Minimum	m	30/5	50/5
	Maximum Operating Current	A	4.94	6.75
	Base charge refrigerant level	Kg	1	1.1
	Suggested Fuse Size	A	10	10

All data is based on Toshiba Nominal Conditions as described in the back of our standard price list.

TOSHIBA AIRCONDITIONINGAdvancing the **eco** - evolution

Super Digital Inverter Slim Ducted Heat Pump System

INDOOR UNITS

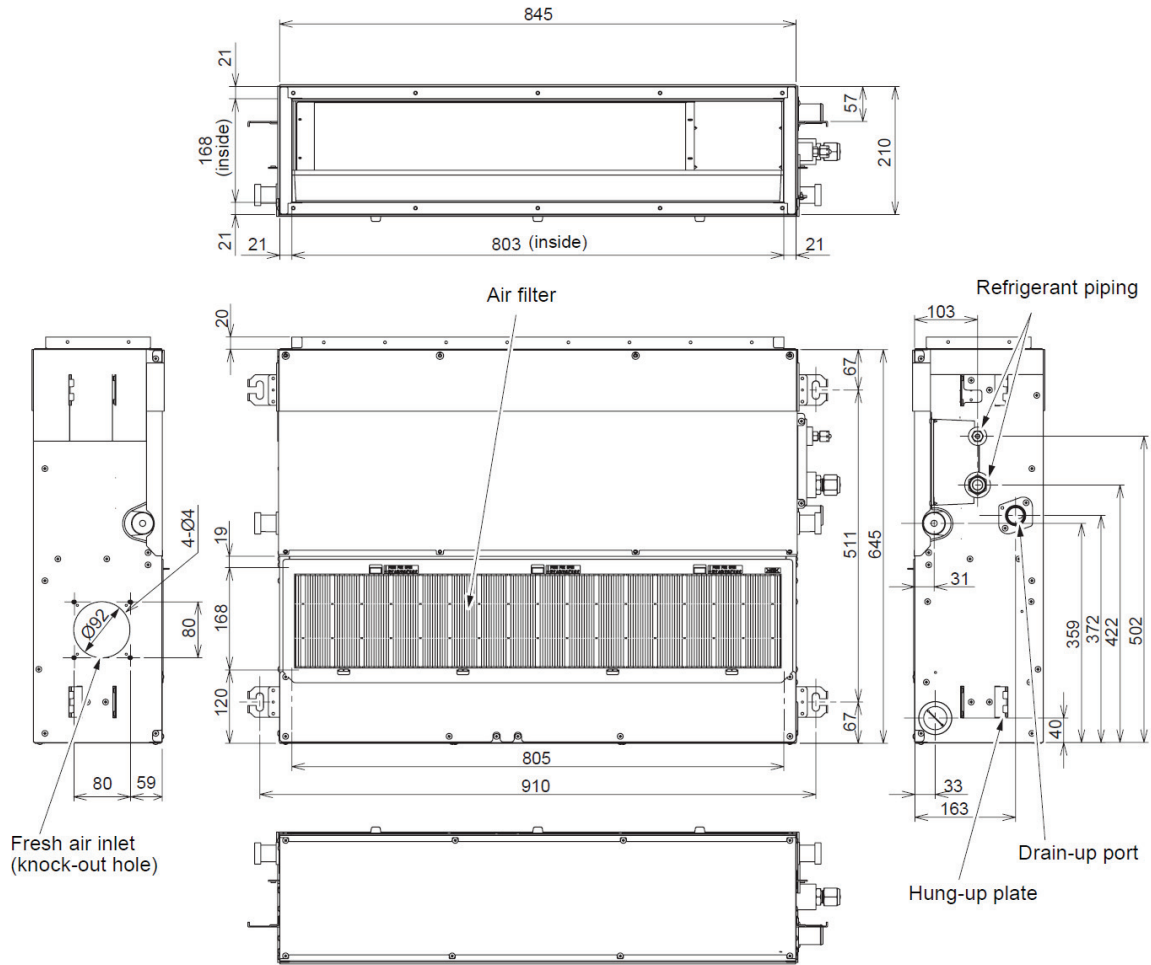

RAV-SM404SDT-E and RAV-SM564SDT-E

OUTDOOR UNITS

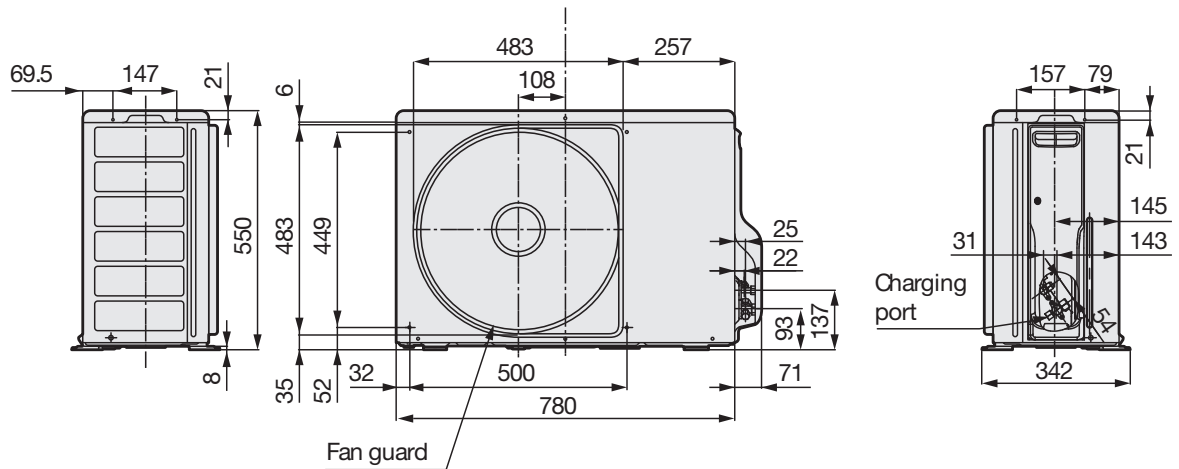

RAV-SP404AT-E and RAV-SP564AT-E

