

# TOSHIBA

Leading Innovation >>>



## High Wall Heat Pump System

Digital Inverter features, plus:

- New compact flat-panel
- Increases energy efficiency/cost savings
- New fan motor and enhanced compressor design
- Extended pipe runs/greater installation flexibility
- More control steps for more precise inverter control
- Infra-red control available
- EER values up to 3.80 in cooling mode
- Superior five-stage air filtration system

With its slim-line design the Super Digital Inverter high wall unit is ideal for offices, restaurants and other applications where elegance is required.

The units are suitable for use with either new R410A refrigerant pipe work, or indeed can be used as 'replacement technology' enabling the re-use of existing R22 or R407c Pipe work.



Size 564

Size 804

Model	Outdoor Unit	RAV	SP564AT-E	SP804AT-E
	Indoor Unit	RAV	SM562KRT-E	SM802KRT-E
System Data	Cooling Capacity (Range)	kW	5.0 (1.2-5.6)	6.9 (1.9-8.0)
	Heating Capacity (Range)	kW	5.6 (0.9-7.3)	8.0 (1.3-10.6)
	Power Input, Cooling/Heating	kW	1.56/1.55	2.40/2.40
	COP	W/W	3.61	3.33
	EER	W/W	3.21	2.88
	SEER	W/W	4.33	4.14
	Annual Power Consumption, Cooling	kWh	780	1200
	Energy Label, Cooling / Heating		A/A	C/C
	UK Conditions - Cooling Capacity	kW	5.44	7.76
	UK Conditions - Sensible Cooling Capacity	kW	4.22	5.85
UK Conditions - Heating Capacity	kW	4.69	6.7	
Indoor	Air flow (High/Medium/Low)	l/s	178/208/233	203/243/308
	Sound Pressure Level (High/Medium/Low)	dB(A)	36/41/45	36/41/45
Outdoor	Airflow	l/s (m3/h)	667 (2400)	833 (3000)
	Sound Pressure Level (cooling/heating)	dB(A)	47/48	48/49
	Pipe Connections, Gas - Liquid	in	1/2 - 1/4	5/8 - 3/8
	Pipe Length, Maximum/Minimum	m	50/5	50/5
	Maximum Operating Current	A	8.14	12.91
	Base charge refrigerant level	Kg	1.1	2
	Suggested Fuse Size	A	10	10

All data is based on Toshiba Nominal Conditions as described in the back of our standard price list.

**TOSHIBA AIRCONDITIONING**  
Advancing the **eco** - evolution

Super Digital Inverter High Wall Heat Pump

## INDOOR UNITS

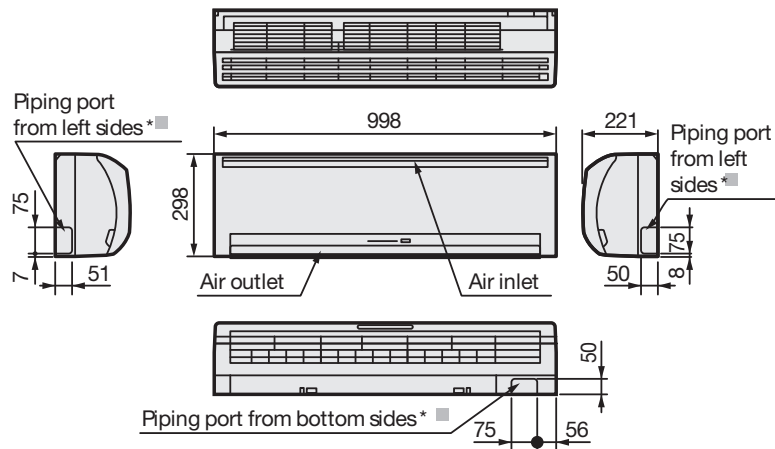

RAV-SM562KRT-E and RAV-SM802KRT-E

## OUTDOOR UNITS

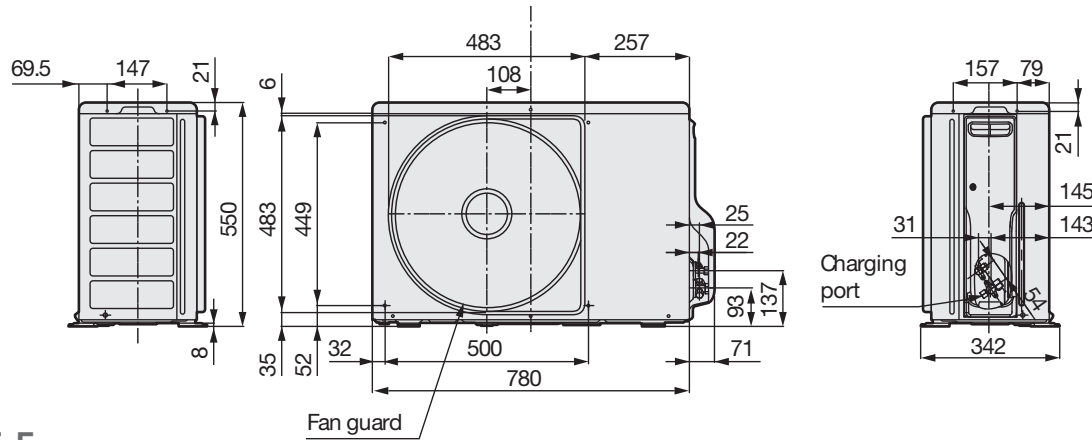

RAV-SP564AT-E

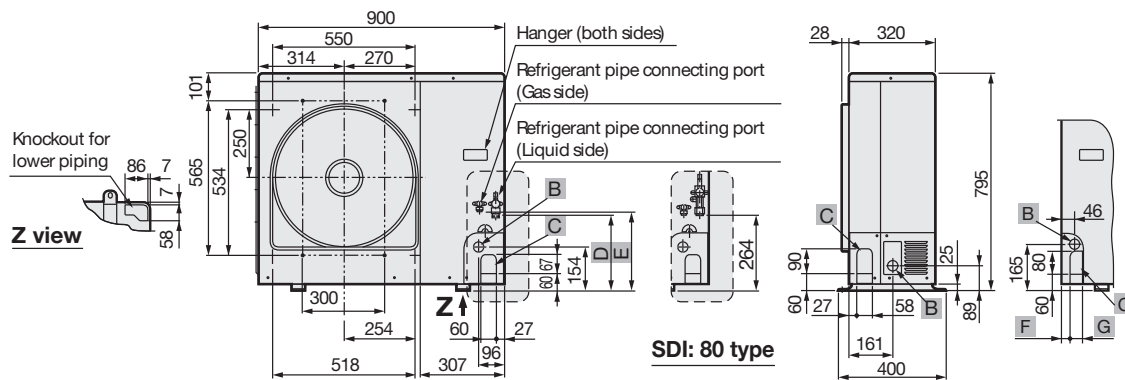

RAV-SP804AT-E