

TOSHIBA

Leading Innovation >>>

Slim Ducted Heat Pump System

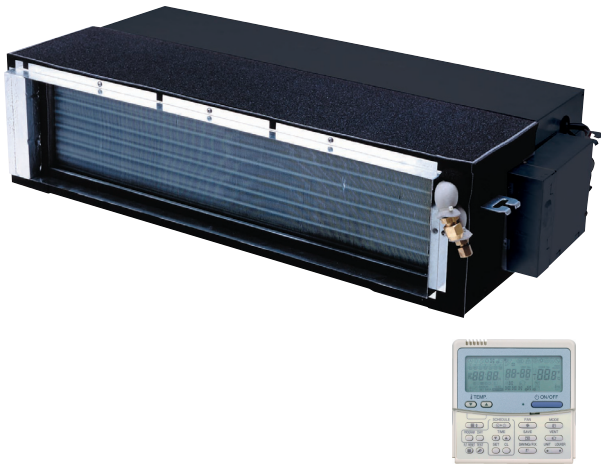

- High Efficiency Twin Rotary Inverter Compressor
- Utilises R410A none ozone depleting refrigerant
- Replacement Technology (R22 & R407c)
- Slim 210mm deep ducted unit design
- Static pressure up to 45 Pa
- Extremely quiet operation
- Twin split also available
- Infra-red and wired controls available
- Operational to -15°C in Cooling & Heating
- Power Supply to Outdoor Unit

The Slim Ducted unit is a very compact unit with low height dimensions for flexible ceiling installations.

The units are suitable for use with either new R410A refrigerant pipe work, or indeed can be used as 'replacement technology' enabling the re-use of existing R22 or R407c Pipe work.

Key features include high energy efficiency performances in cooling and heating and a choice of two selections for the air inlet section: bottom or back side.



Size 563

Model	Outdoor Unit	RAV	SM563AT-E
	Indoor Unit	RAV	SM564SDT-E
System Data	Cooling Capacity (Range)	kW	5.0 (1.5-5.6)
	Heating Capacity (Range)	kW	5.6 (1.5-6.3)
	Power Input, Cooling/Heating	kW	1.78/1.71
	COP	W/W	3.52
	EER	W/W	3.01
	SEER	W/W	4.26
	Annual Power Consumption, Cooling	kWh	890
	Energy Label, Cooling / Heating		C/C
	UK Conditions - Cooling Capacity	kW	5.22
UK Conditions - Sensible Cooling Capacity	kW	3.88	
UK Conditions - Heating Capacity	kW	5.98	
Indoor	Air flow (High/Medium/Low)	l/s	162/188/217
	Sound Pressure Level (High/Medium/Low)	dB(A)	36/40/45
Outdoor	Airflow	l/s (m3/h)	667 (2400)
	Sound Pressure Level (cooling/heating)	dB(A)	46/48
	Pipe Connections, Gas - Liquid	in	1/2 - 1/4
	Pipe Length, Maximum/Minimum	m	30/5
	Maximum Operating Current	A	7.9
	Base charge refrigerant level	Kg	1
	Suggested Fuse Size	A	10

All data is based on Toshiba Nominal Conditions as described in the back of our standard price list.

Digital Inverter Slim Ducted Heat Pump System

TOSHIBA AIRCONDITIONING

Advancing the **eco**-evolution



INDOOR UNITS

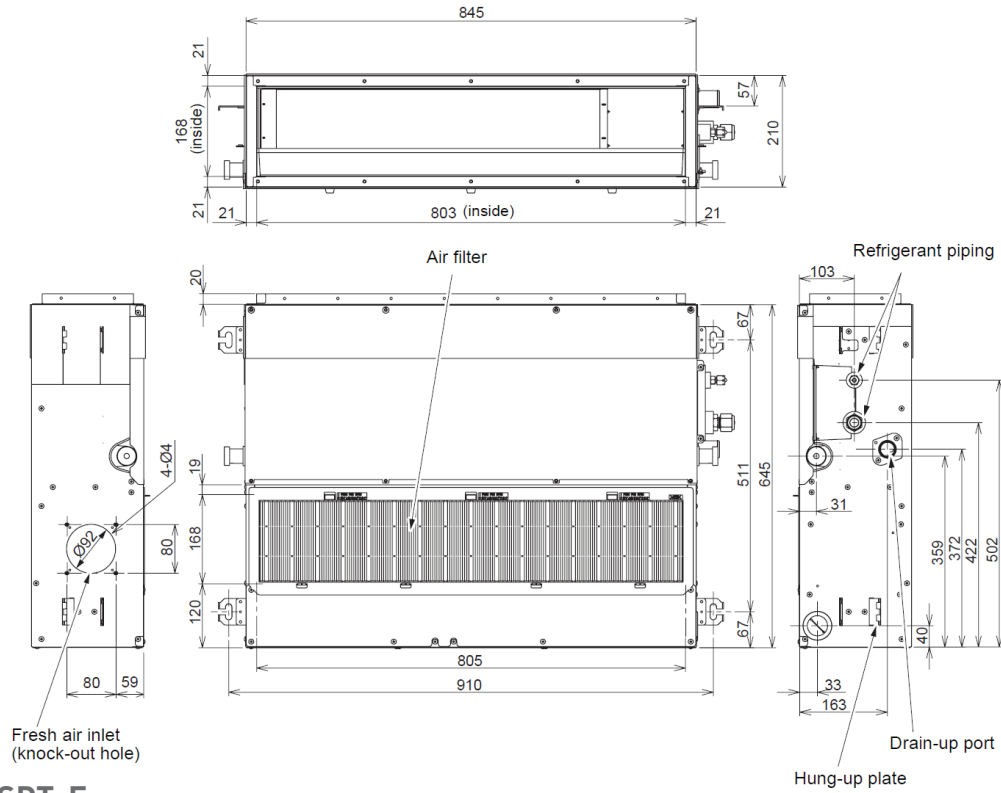

RAV-SM564SDT-E

OUTDOOR UNITS

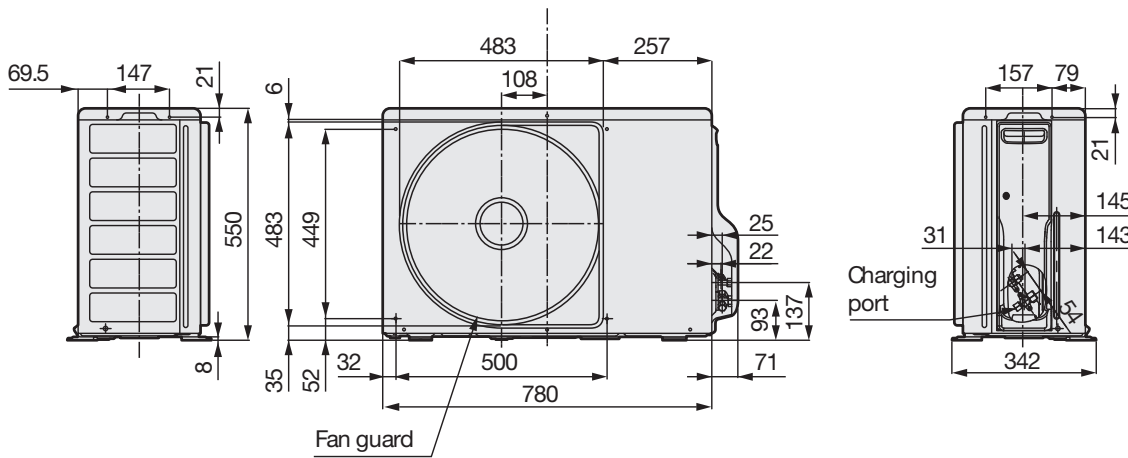

RAV-SM563AT-E

