

TOSHIBA

Leading Innovation >>>



High Wall Heat Pump System

- High Efficiency Twin Rotary Inverter Compressor
- Utilises R410a none ozone depleting Refrigerant
- Replacement Technology (R22 & R407c)
- High-performance operation, using digital inverter control system
- Enhanced filtration system
- TCC Link remote control (optional)
- Auto louvre mode allows optimum air distribution
- Infra-red and wired controls available

With its slim-line design the Digital Inverter high wall unit is ideal for offices, restaurants and other applications where elegance is required.

The units are suitable for use with either new R410A refrigerant pipe work, or indeed can be used as 'replacement technology' enabling the re-use of existing R22 or R407c Pipe work.



Size 563 & 803

Model	Outdoor Unit	RAV	SM563AT-E	SM803AT-E
	Indoor Unit	RAV	SM562KRT-E	SM802KRT-E
System Data	Cooling Capacity (Range)	kW	5.1 (1.5-5.6)	6.7 (1.5-8.0)
	Heating Capacity (Range)	kW	5.6 (1.5-6.3)	8.0 (1.5-9.0)
	Power Input, Cooling/Heating	kW	1.74/1.70	2.72/2.67
	COP	W/W	3.29	3
	EER	W/W	2.93	2.46
	SEER	W/W	3.83	3.66
	Annual Power Consumption, Cooling	kWh	870	1360
	Energy Label, Cooling / Heating		C/C	E/D
	UK Conditions - Cooling Capacity	kW	5.44	7.76
	UK Conditions - Sensible Cooling Capacity	kW	4.22	5.85
UK Conditions - Heating Capacity	kW	4.69	6.7	
Indoor	Air flow (High/Medium/Low)	l/s	178/208/233	203/243/308
	Sound Pressure Level (High/Medium/Low)	dB(A)	33/36/39	36/41/45
Outdoor	Airflow	l/s (m3/h)	667 (2400)	750 (2700)
	Sound Pressure Level (cooling/heating)	dB(A)	63/65	65/67
	Pipe Connections, Gas - Liquid	in	1/2 - 1/4	5/8 - 3/8
	Pipe Length, Maximum/Minimum	m	30/5	30/5
	Maximum Operating Current	A	7.3	11.32
	Base charge refrigerant level	Kg	1	1.7
	Suggested Fuse Size	A	10	16

All data is based on Toshiba Nominal Conditions as described in the back of our standard price list.

TOSHIBA AIRCONDITIONING

Advancing the **eco** -evolution

Digital Inverter High Wall Heat Pump System



INDOOR UNITS

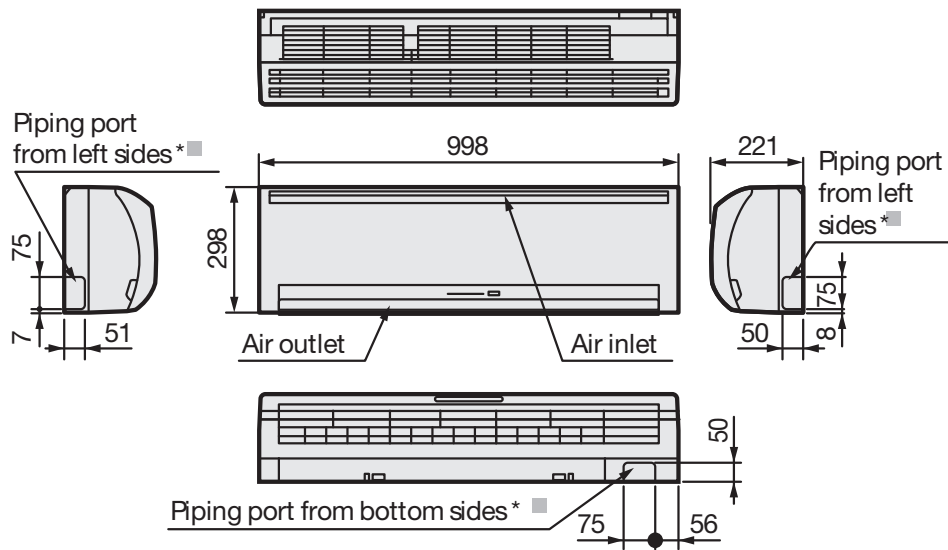

RAV-SM562KRT-E and RAV-SM802KRT-E

OUTDOOR UNITS

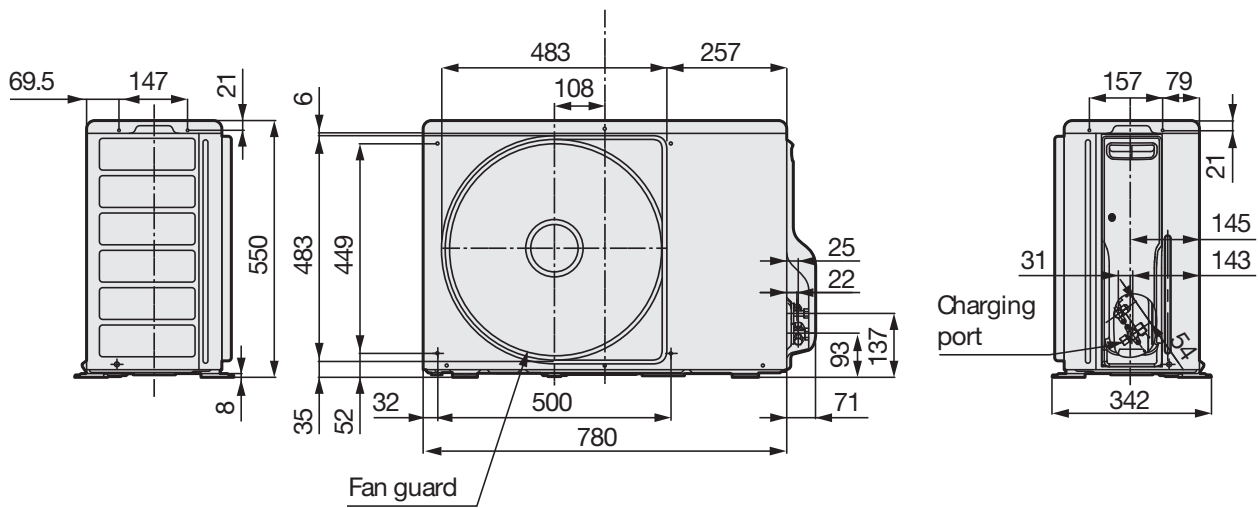

RAV-SM563AT-E and RAV-SM803AT-E

