

# TOSHIBA

Leading Innovation >>>

## Ducted Unit Heat Pump System



- Unobtrusive installation above suspended ceilings for different room layout and a wide range of applications
- High-performance operation, using digital inverter control, infra-red and wired controls available
- High static pressure up to 98 Pa
- High-lift drain pump kit to 550mm
- Uniform temperatures throughout the room
- Extremely quiet operation
- Twin-split also available
- Ideal for R22 and R407c replacement

The Digital Inverter series of ducted units can be discreetly positioned in the walls or ceiling. They are ideal for hotels, banks and similar applications, where very low noise levels are needed.

Due to Toshiba's very own Hybrid Inverter Drive they offer high performance, utilizing minimum energy to lower energy costs.

The units are suitable for use with either new R410A refrigerant pipe work, or indeed can be used as 'replacement technology' enabling the re-use of existing R22 or R407c Pipe work.



Size 563 & 803

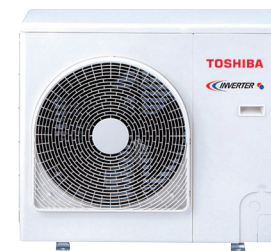

Size 1103 & 1403

Model	Outdoor Unit	RAV	SM563AT-E	SM803AT-E	SM1103AT-E	SM1403AT-E
	Indoor Unit	RAV	SM562BT-E	SM802BT-E	SM1102BT-E	SM1402BT-E
System Data	Cooling Capacity (Range)	kW	5.0 (1.5-5.6)	7.1 (1.5-8.0)	10 (3-11.2)	12.1 (3-13.2)
	Heating Capacity (Range)	kW	5.6 (1.5-6.3)	8 (1.5-9)	11.2 (3-12.5)	14 (3-16)
	Power Input, Cooling/Heating	kW	1.78/1.71	2.53/2.41	3.56/3.14	4.42/4.03
	COP	W/W	3.27	3.32	3.57	3.47
	EER	W/W	2.81	2.81	2.81	2.83
	SEER	W/W	3.6	4.11	4.26	4.29
	Annual Power Consumption, Cooling	kWh	890	1265	1780	2210
	Energy Label, Cooling / Heating	C/C	C/C	C/C	C/B	C/B
	UK Conditions - Cooling Capacity	kW	5.44	7.76	10.87	12.81
	UK Conditions - Sensible Cooling Capacity	kW	4.2	5.85	7.64	8.73
UK Conditions - Heating Capacity	kW	4.69	6.7	9.31	11.92	
Indoor	Air flow (High/Medium/Low)	l/s	161/198/217	222/270/317	315/383/450	385/467/550
	Sound Pressure Level (High/Medium/Low)	dB(A)	33/37/40	34/37/40	36/39/42	38/41/44
Outdoor	Airflow	l/s (m3/h)	667 (2400)	750 (2700)	1250 (4500)	1250 (4500)
	Sound Pressure Level (cooling/heating)	dB(A)	46/48	48/50	53/54	53/54
	Pipe Connections, Gas - Liquid	in	1/2 - 1/4	5/8 - 3/8	5/8 - 3/8	5/8 - 3/8
	Pipe Length, Maximum/Minimum	m	30/5	30/5	50/5	50/5
	Maximum Operating Current	A	7.9	10.1	14.4	17.7
	Base charge refrigerant level	Kg	1	1.7	2.8	2.8
	Suggested Fuse Size	A	10	16	20	20

All data is based on Toshiba Nominal Conditions as described in the back of our standard price list.

Digital Inverter Ducted Unit Heat Pump System

TOSHIBA AIRCONDITIONING

Advancing the **eco**-evolution

## INDOOR UNITS

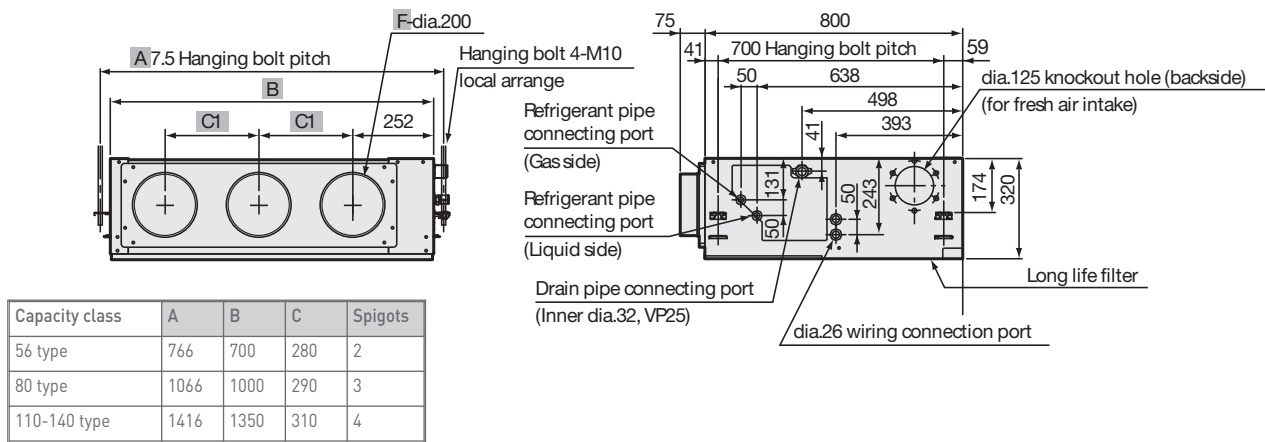

RAV-SM562BT-E, RAV-SM802BT-E, RAV-SM1102BT-E and RAV-SM1402BT-E

## OUTDOOR UNITS

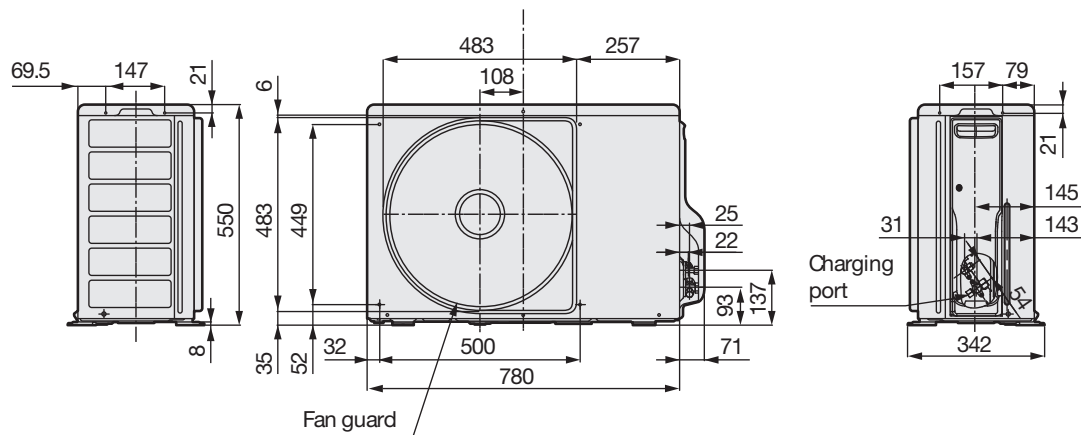

RAV-SM563AT-E and RAV-SM803AT-E

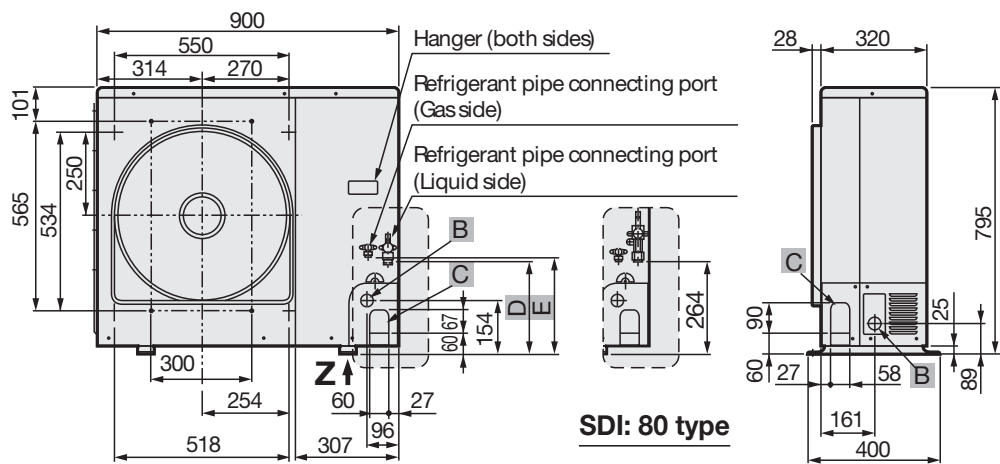

RAV-SM1103AT-E and RAV-SM1403AT-E

