

TOSHIBA

Leading Innovation >>>



Compact 4 Way Cassette Heat Pump

- Compact 600 x 600mm cassette
- High Efficiency Twin Rotary Inverter Compressor
- Utilises R410a none ozone depleting Refrigerant
- Replacement Technology (R22 & R407c)
- Light weight & very easy to Install
- Panel depth less than 30mm
- Self Cleaning Function & Anti mold drain pan
- Removable Corner Pockets for easy access
- Infra-red and wired controls available
- Detachable Louvre and Grille for Easy Cleaning
- Power Supply to Outdoor Unit

This 4-way cassette has been designed to suit all standard 600 x 600mm grid ceilings, for easy installation and maintenance.

The Digital Inverter Series of cassettes are compact, unobtrusive and flexible which can easily blend in with any room interior. They offer a high performance utilizing minimum energy to help lower your power consumption.

The units are suitable for use with either new R410A refrigerant pipe work, or indeed can be used as 'replacement technology' enabling the re-use of existing R22 or R407c Pipe work.



Size 563

Model	Outdoor Unit	RAV	SM563AT-E
	Indoor Unit	RAV	SM562MUT-E
	Panel	RBC	UM11PG(W)-E
System Data	Cooling Capacity (Range)	kW	5.0 (1.5-5.6)
	Heating Capacity (Range)	kW	5.6 (1.5-6.3)
	Power Input, Cooling/Heating	kW	1.61/1.61
	COP	W/W	3.48
	EER	W/W	3.11
	SEER	W/W	3.88
	Annual Power Consumption, Cooling	kWh	805
	Energy Label, Cooling / Heating		B/B
	UK Conditions - Cooling Capacity	kW	5.44
	UK Conditions - Sensible Cooling Capacity	kW	4.22
UK Conditions - Heating Capacity	kW	4.69	
Indoor	Air flow (High/Medium/Low)	l/s	145/211
	Sound Pressure Level (High/Medium/Low)	dB(A)	39/44
Outdoor	Airflow	l/s (m3/h)	667 (2400)
	Sound Pressure Level (cooling/heating)	dB(A)	46/48
	Pipe Connections, Gas - Liquid	in	1/2 - 1/4
	Pipe Length, Maximum/Minimum	m	30/5
	Maximum Operating Current	A	7.9
	Base charge refrigerant level	Kg	1
	Suggested Fuse Size	A	10

All data is based on Toshiba Nominal Conditions as described in the back of our standard price list.

Digital Inverter Compact 4 Way Cassette Heat Pump

TOSHIBA AIRCONDITIONING

Advancing the **eco**-evolution

INDOOR UNITS

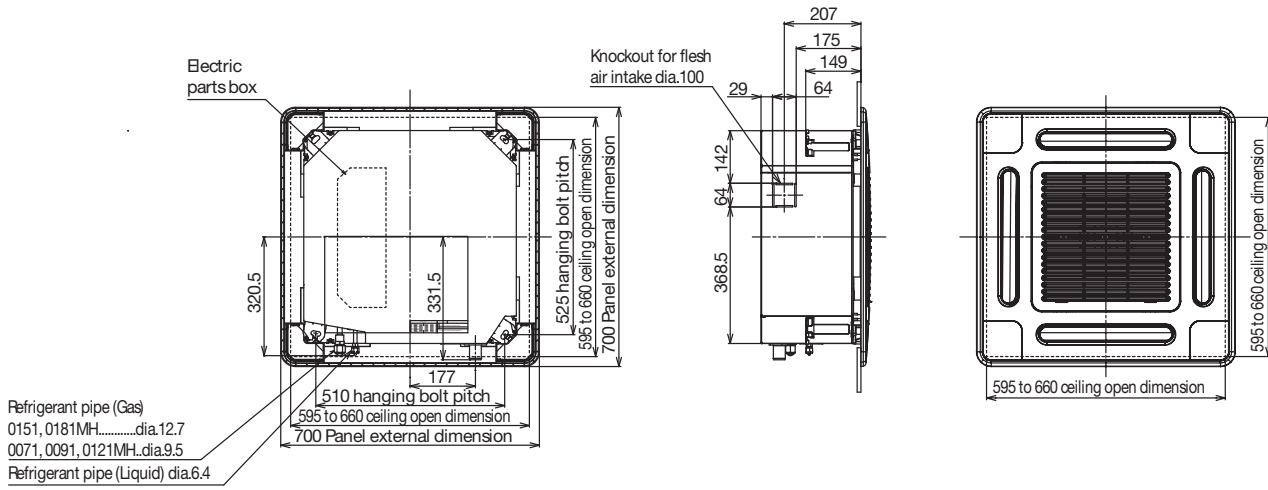

RAV-SM562MUT-E

OUTDOOR UNITS

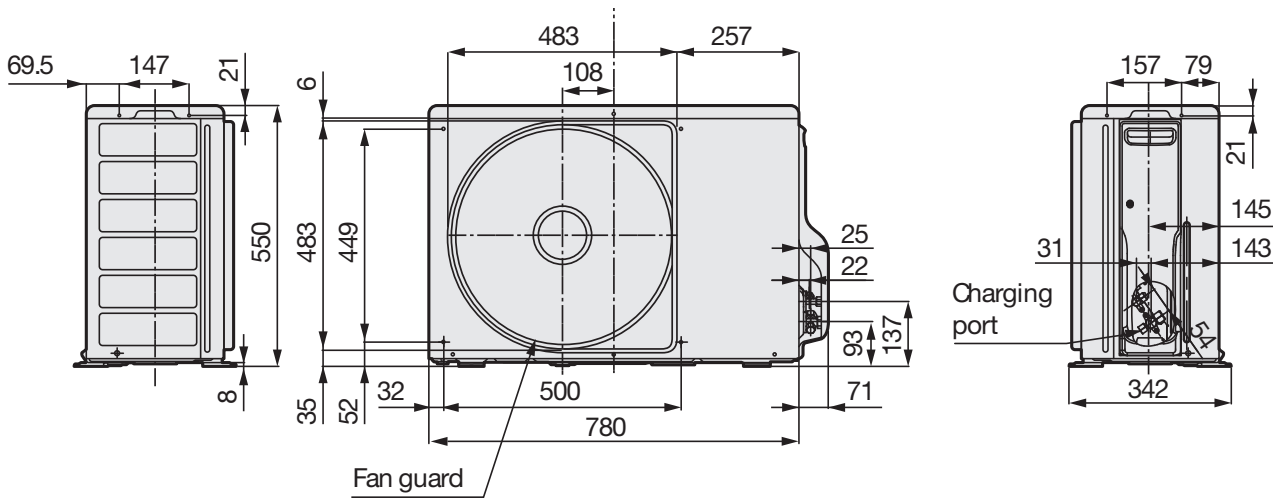

RAV-SM563AT-E



TOSHIBA

Leading Innovation >>>



Compact 4 Way Cassette Heat Pump

- Compact 600 x 600mm cassette
- High Efficiency Twin Rotary Inverter Compressor
- Utilises R410a none ozone depleting Refrigerant
- Replacement Technology (R22 & R407c)
- Light weight & very easy to Install
- Panel depth less than 30mm
- Self Cleaning Function & Anti mold drain pan
- Removable Corner Pockets for easy access
- Infra-red and wired controls available
- Detachable Louvre and Grille for Easy Cleaning
- Power Supply to Outdoor Unit

This 4-way cassette has been designed to suit all standard 600 x 600mm grid ceilings, for easy installation and maintenance.

The Digital Inverter Series of cassettes are compact, unobtrusive and flexible which can easily blend in with any room interior. They offer a high performance utilizing minimum energy to help lower your power consumption.

The units are suitable for use with either new R410A refrigerant pipe work, or indeed can be used as 'replacement technology' enabling the re-use of existing R22 or R407c Pipe work.



Size 563

Model	Outdoor Unit	RAV	SM563AT-E
	Indoor Unit	RAV	SM562MUT-E
	Panel	RBC	UM11PG(W)-E
System Data	Cooling Capacity (Range)	kW	5.0 (1.5-5.6)
	Heating Capacity (Range)	kW	5.6 (1.5-6.3)
	Power Input, Cooling/Heating	kW	1.61/1.61
	COP	W/W	3.48
	EER	W/W	3.11
	SEER	W/W	3.88
	Annual Power Consumption, Cooling	kWh	805
	Energy Label, Cooling / Heating		B/B
	UK Conditions - Cooling Capacity	kW	5.44
	UK Conditions - Sensible Cooling Capacity	kW	4.22
UK Conditions - Heating Capacity	kW	4.69	
Indoor	Air flow (High/Medium/Low)	l/s	145/211
	Sound Pressure Level (High/Medium/Low)	dB(A)	39/44
Outdoor	Airflow	l/s (m3/h)	667 (2400)
	Sound Pressure Level (cooling/heating)	dB(A)	46/48
	Pipe Connections, Gas - Liquid	in	1/2 - 1/4
	Pipe Length, Maximum/Minimum	m	30/5
	Maximum Operating Current	A	7.9
	Base charge refrigerant level	Kg	1
	Suggested Fuse Size	A	10

All data is based on Toshiba Nominal Conditions as described in the back of our standard price list.

Digital Inverter Compact 4 Way Cassette Heat Pump

TOSHIBA AIRCONDITIONING

Advancing the **eco**-evolution

INDOOR UNITS

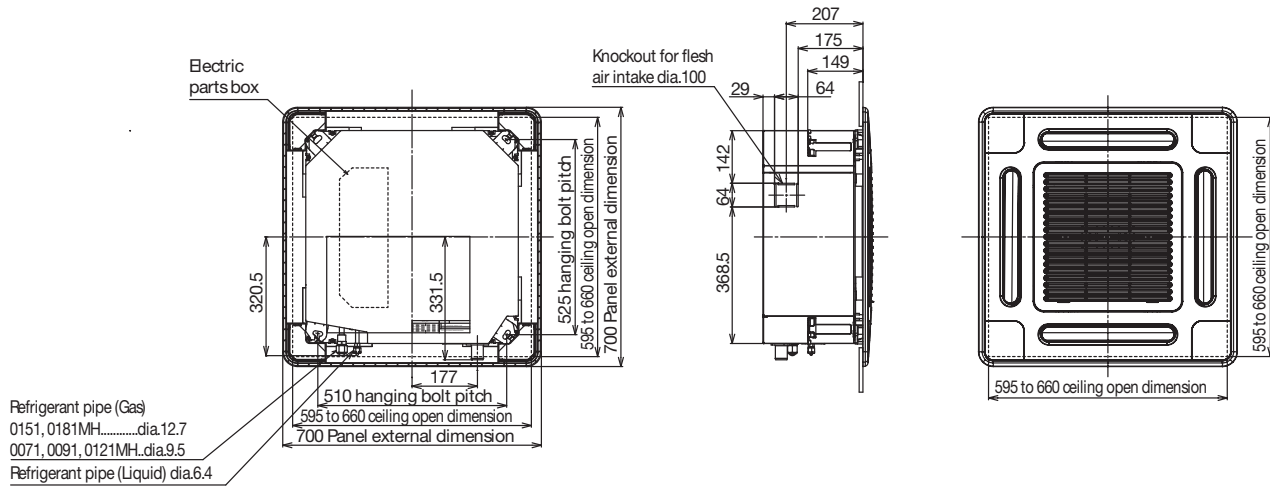

RAV-SM562MUT-E

OUTDOOR UNITS

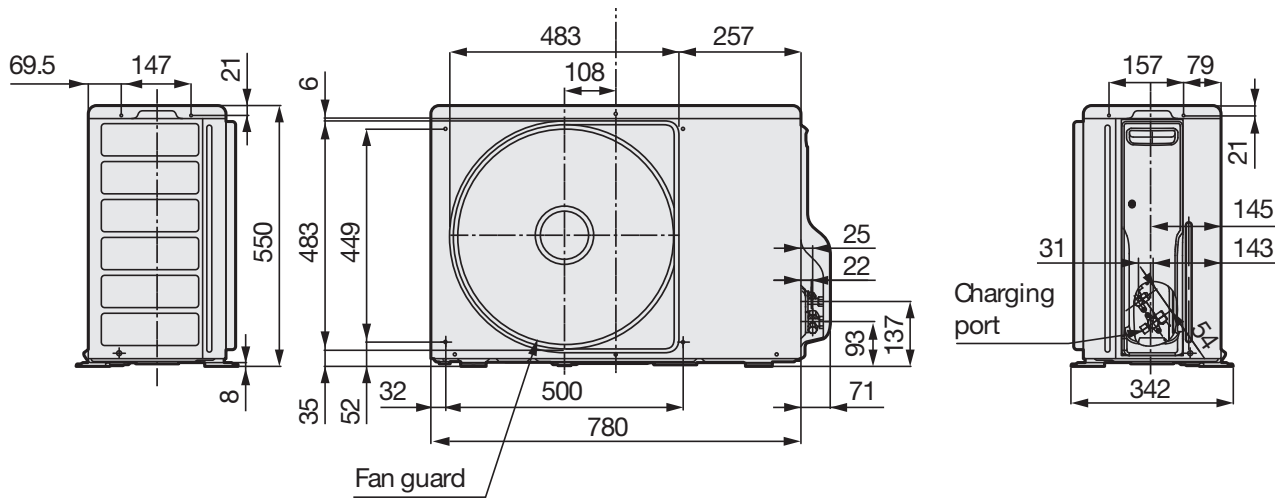

RAV-SM563AT-E

Toshiba Carrier UK Ltd
 United Technologies House
 Guildford Road
 Leatherhead
 Surrey KT22 9UT

Marketing.uk@toshiba-ac.com
 www.toshiba-aircon.co.uk