

TOSHIBA

Leading Innovation >>>



Ceiling Suspended Heat Pump System

- Easy installation and maintenance
- High-performance operation, using digital inverter control
- Infra-red and wired controls available
- Operational at 30 dB(A), twice as quiet as conventional units
- Automatic louvre control for cooling and heating modes plus auto-swing
- Uniform temperatures throughout the room
- Mould-proof, fully recyclable drain pan
- Twin-split also available
- Ideal for R22 and R407c replacement

The Digital Inverter series of ceiling suspended units can be discreetly positioned under the ceilings. They are ideal for offices, classrooms and restaurants, where very low noise levels are required.

The automatic louvre control and low noise levels are the key characteristics of this state-of-the-art unit.

The units are suitable for use with either new R410A refrigerant pipe work, or indeed can be used as 'replacement technology' enabling the re-use of existing R22 or R407c Pipe work.



Size 563 & 803

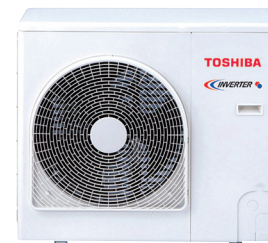

Size 1103 & 1403

Model	Outdoor Unit	RAV	SM563AT-E	SM803AT-E	SM1103AT-E	SM1403AT-E
	Indoor Unit	RAV	SM562CT-E	SM802CT-E	SM1102CT-E	SM1402CT-E
System Data	Cooling Capacity (Range)	kW	5.0 (1.5-5.6)	7.0 (1.5-8.0)	10.0 (3.0-11.2)	12.3 (3.0-13.2)
	Heating Capacity (Range)	kW	5.6 (1.5-6.3)	8.0 (1.5-9.0)	11.2 (3.0-12.5)	14.0 (3.0-16.0)
	Power Input, Cooling/Heating	kW	1.82/1.64	2.53/2.47	3.51/3.20	4.52/4.14
	COP	W/W	3.41	3.24	3.5	3.38
	EER	W/W	2.75	2.77	2.85	2.72
	SEER	W/W	3.51	4.05	4.29	4.14
	Annual Power Consumption, Cooling	kWh	910	1265	1755	2260
	Energy Label, Cooling / Heating		D/B	D/C	C/B	D/C
	UK Conditions - Cooling Capacity	kW	5.44	7.76	11.65	13.59
	UK Conditions - Sensible Cooling Capacity	kW	4.22	5.85	7.73	8.75
UK Conditions - Heating Capacity	kW	5.21	7.08	9.68	12.29	
Indoor	Air flow (High/Medium/Low)	l/s	167/186/217	243/278/308	353/400/458	385/433/500
	Sound Pressure Level (High/Medium/Low)	dB(A)	30/33/36	33/36/38	35/38/41	37/40/43
Outdoor	Airflow	l/s (m3/h)	667 (2400)	750 (2700)	1250 (4500)	1250 (4500)
	Sound Pressure Level (cooling/heating)	dB(A)	46/48	48/50	53/54	53/54
	Pipe Connections, Gas - Liquid	in	1/2 - 1/4	5/8 - 3/8	5/8 - 3/8	5/8 - 3/8
	Pipe Length, Maximum/Minimum	m	30/5	30/5	50/5	50/5
	Maximum Operating Current	A	7.9	10.3	15	17.6
	Base charge refrigerant level	Kg	1	1.7	2.8	2.8
	Suggested Fuse Size	A	10	16	20	20

All data is based on Toshiba Nominal Conditions as described in the back of our standard price list.

Digital Inverter Ceiling Suspended Heat Pump

TOSHIBA AIRCONDITIONING

Advancing the **eco**-evolution

INDOOR UNITS

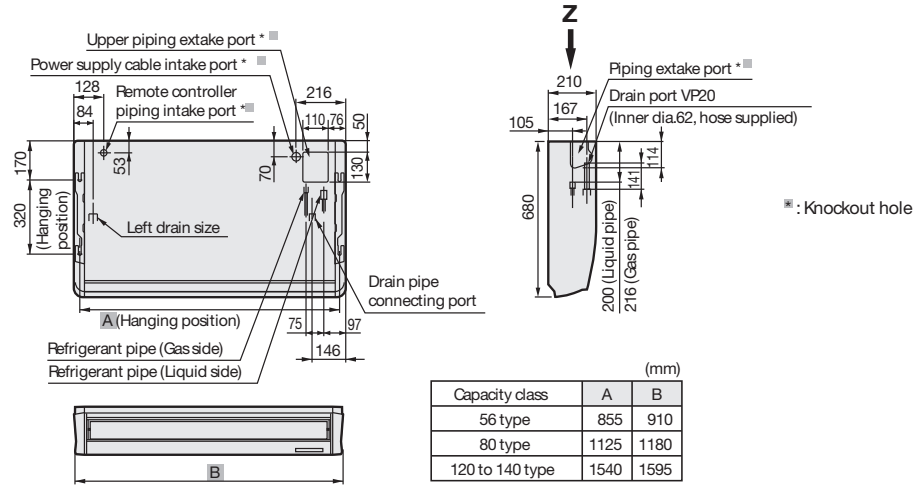

RAV-SM562CT-E, RAV-SM802CT-E, RAV-SM1102CT-E and RAV-SM1402CT-E

OUTDOOR UNITS

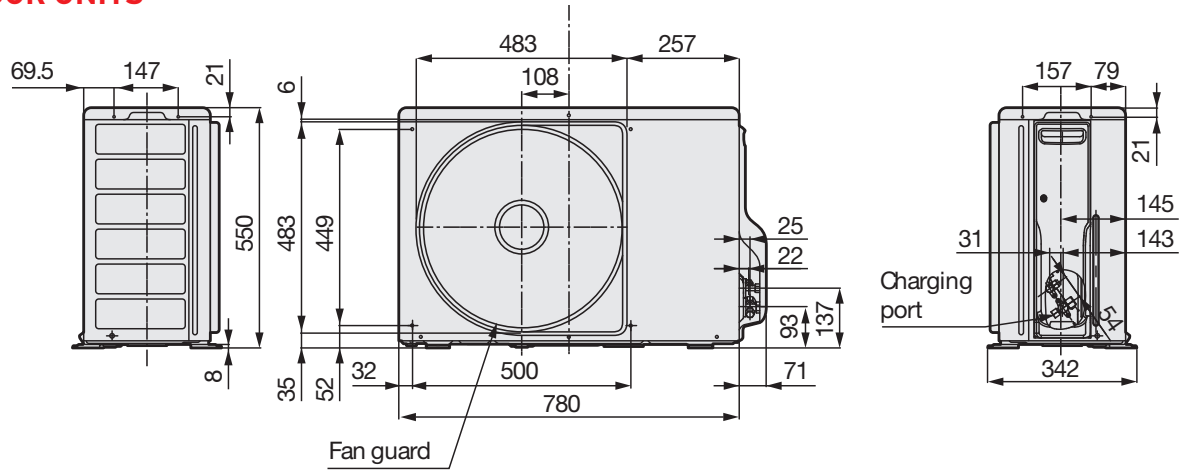

RAV-SM563AT-E and RAV-SM803AT-E

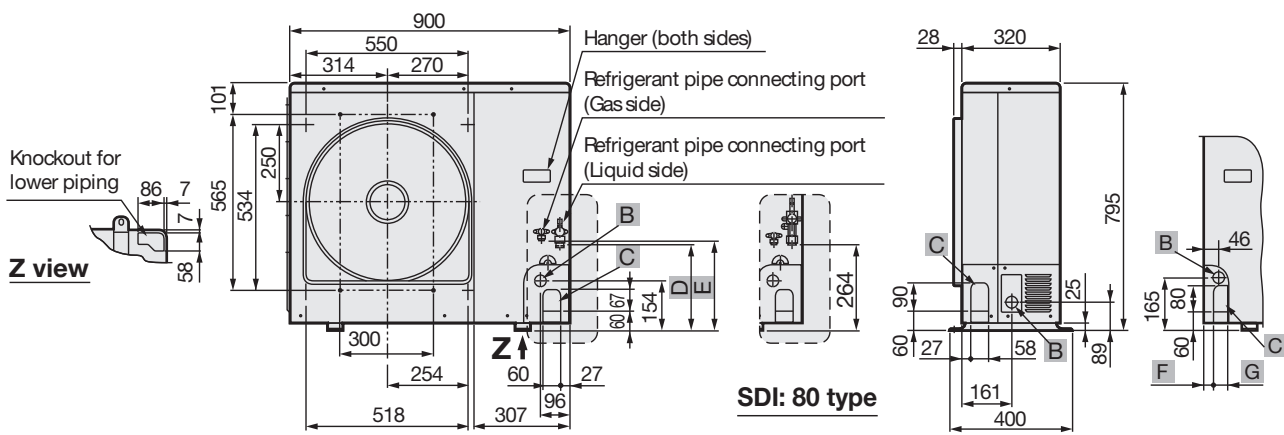

RAV-SM1103AT-E and RAV-SM1403AT-E

